

**I O M**  
INSTALL-OPERATE-MAINTAIN

**L Series type-B  
Spring Return Actuators**

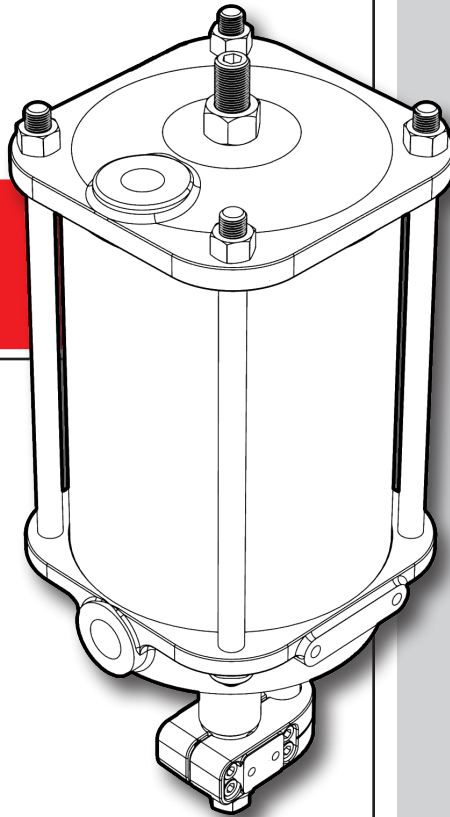

QTRCO L-series actuators are linear type actuators.

These actuators adhere to QTRCO design standards for long, maintenance free life.

This manual describes the proper methods for installation, operation, and repair maintenance.

LINEAR  
PNEUMATIC ACTUATORS



**The Leader in Actuator Technology**



**NOTE:**

ALL ACTIVITIES MUST BE CARRIED OUT IN ORDER TO ENSURE PROPER ACTUATOR OPERATION.  
ALWAYS READ ALL INSTRUCTIONS BEFORE BEGINNING MAINTENANCE.

Every actuator assembled by QTRCO is tested prior to shipment to our customers.  
Order specific documentation may be available upon request.

Contact QTRCO with any questions at [info@qtrco.com](mailto:info@qtrco.com) or 281-516-0277.

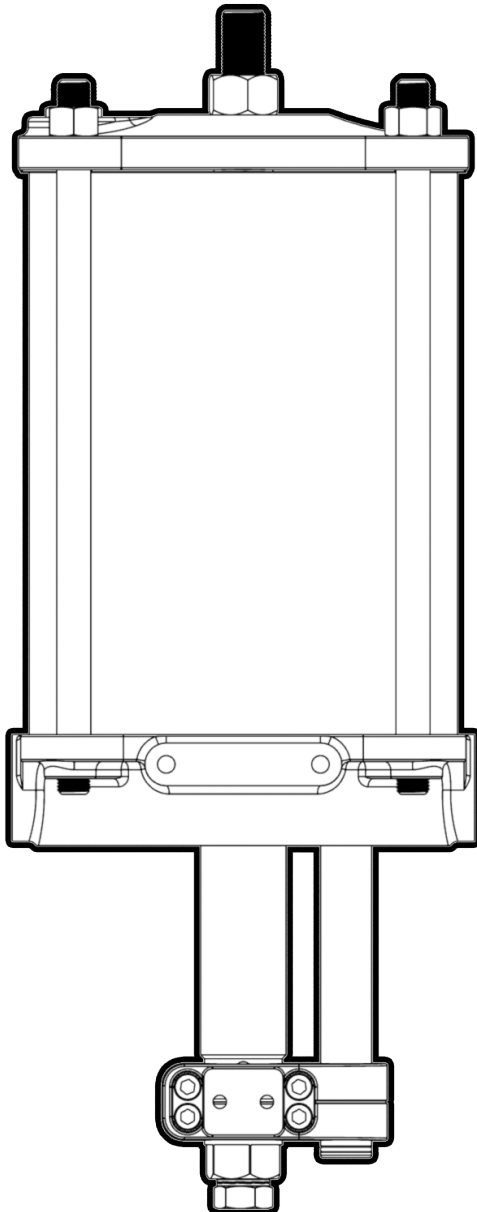

## CONTENTS

1. INSTALLATION	4
1.1 VALVE ATTACHMENT	5
1.2 ACCESSORY MOUNTING	5
1.3 PIPING AND OPERATION	5
1.4 TRAVEL ADJUSTMENT	8
2. TROUBLESHOOTING	10
3. MAINTENANCE	11
3.1 PERIODIC MAINTENANCE SCHEDULE	11
3.2 LUBRICATION	11
3.3 MAINTENANCE KIT	12
3.4 PISTON O-RING REPLACEMENT	12
3.5 ROD SEAL AND BUSHING REPLACEMENT	13
3.6 OUTPUT ROD REPLACEMENT	13
3. APPENDIX	14

## 1. INSTALLATION

QTRCO actuators may be mounted in any position/orientation. If necessary, lift the actuator with straps placed inside the framework of the bracket. **NEVER lift the actuator by the cylinders or tie rods.** Lifting eyes may be used to lift the actuator only. Lifting with the valve attached is prohibited.

Use the provided lifting points for vertical lifting only. Always ensure that lifting straps are pulling in the plane of the eye. Never reeve a single strap, chain, or cable through multiple lifting eyes. Never use actuator lifting points to lift people or objects over people.

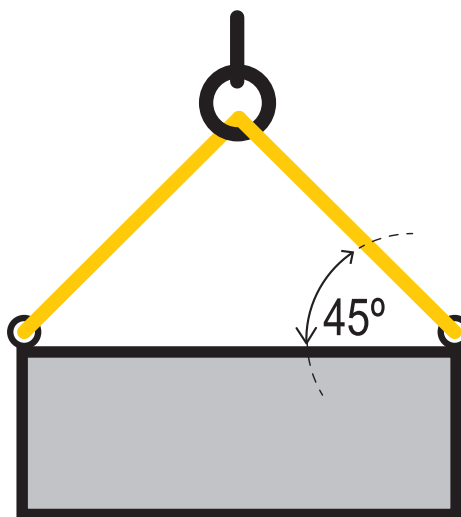
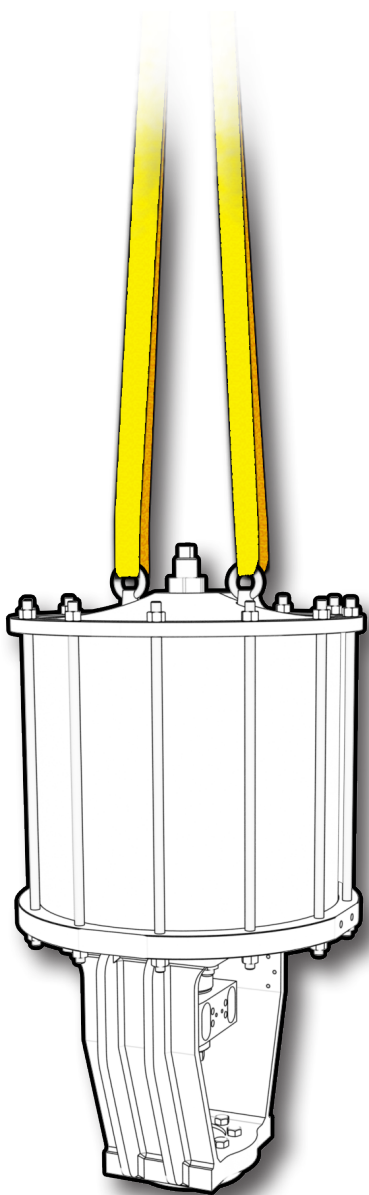

Never lift with straps at an angle less than 45° from horizontal.

### WARNING

INSTALLATION MAY REQUIRE MAINTENANCE PERSONNEL TO WORK IN PINCH POINT AREAS. ALWAYS ENSURE THAT HANDS AND TOOLS ARE CLEAR OF THE BRACKET AREA PRIOR TO OPERATING THE ACTUATOR. DO NOT PLACE HANDS OR TOOLS INSIDE THE BRACKET AREA IF THE ACTUATOR IS AT AN INTERMEDIATE TRAVEL POSITION.



**1.1 VALVE ATTACHMENT**

Rising stem type valves with threaded stems

**NOTE:**

READ ALL MOUNTING INSTRUCTIONS PRIOR TO ACTUATOR INSTALLATION. STEPS SHOWN ASSUME VERTICAL MOUNTING AND SHOULD BE MODIFIED FOR OTHER ORIENTATIONS TO ENSURE SAFE INSTALLATION. FULLY SUPPORT THE VALVE PRIOR TO INSTALLATION.

1. Ensure the retracted travel position is adjusted properly at the end cap travel stop (instructions in section 1.4).

**NOTE:**

SOME MOUNTING KITS MAY BE PROVIDED WITH SLOTTED STEM ADAPTERS THAT DO NOT REQUIRE A JAM NUT OR WEDGE LOCK WASHER.

2. Before installing the actuator, thread the provided jam nut onto the valve stem until it reaches the last thread and install the wedge-lock washer pair onto the valve stem.
3. Thread the stem adapter onto the valve stem until it contacts the wedge-lock washer. Do not tighten.
4. Lift the actuator above the valve. If the valve has threaded yoke boss type mounting, place the locknut that was provided with the valve on the top side of the actuator bracket mounting pad.
5. Lower the actuator onto the valve. Install the yoke lock nut or mounting fasteners hand tight only.
6. If not already installed, slide the anti-rotate bushing onto the anti-rotate pin.
7. If mounting to a Push Down To Close (PDTC) valve: Ensure the actuator output rod is in the fully retracted position. For fail-extend actuators, apply air pressure. For fail-retract actuators, exhaust air pressure.
  - i. Lift the valve stem to the maximum height.
  - ii. With the valve in this position, thread the stem adapter upward until it contacts the actuator output rod.
8. If mounting to a Push Down To Open (PDTO) valve: Ensure the actuator output rod is in the fully extended position. For fail-extend actuators, exhaust air pressure. For fail-retract actuators, apply air pressure.
  - i. Lower the valve stem to the minimum height.
  - ii. With the valve in this position, thread the stem adapter upward until it contacts the actuator output rod.
9. Apply medium strength thread locker to the clamp bolt threads. Thread locker prevents bolt galling and loosening.

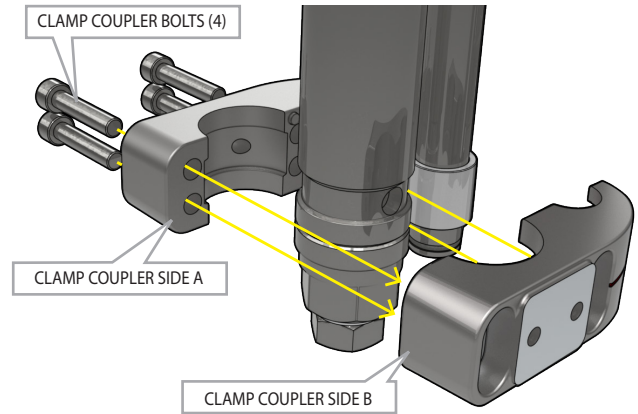

10. Place clamp coupler side B around the output rod and stem adapter, properly locate the anti-rotate bushing, and swing clamp coupler side B into place such that it captures the anti-rotate bushing.
11. Install clamp coupler side A and secure with provided clamp bolts. Tighten in an alternating pattern to keep the clamp couplers parallel to the front face of the actuator. Torque to the values in the table below:

	<b>Thread Size</b>	<b>Hex Drive Size</b>	<b>Ft-Lbs</b>	<b>Nm</b>
L04	M5-0.8	4 mm	3	4
L06	M6-1.0	5 mm	6	8
L08	M8-1.25	6 mm	14	19
L10	M10-1.50	8 mm	27	37
L12	M12-1.75	10 mm	46	62
L14	M14-2.0	12 mm	58	78
L16	M16-2.0	14 mm	90	122
L20	M20-2.5	17 mm	138	187
L24	M24-3.0	19 mm	200	271

12. Once fully tightened, the faces of the clamp coupler should be parallel with the accessory pads on the front and back faces of the actuator base plate. A clamp coupler that is not perfectly aligned will not affect operation, but may impede the proper mounting and adjustment of switch or positioner arms.
13. If the clamp coupler faces are not parallel, loosen and retighten the clamp bolts to adjust.
14. Hold the stem adapter in place with an open-ended wrench and tighten the jam nut against the bottom of the stem adapter.
15. Tighten until the wedge-lock washer is fully compressed plus one-quarter turn.
16. Torque the valve mounting fasteners or lock nut in accordance with valve requirements.



### 1.2 ACCESSORY MOUNTING

L-Series actuators may be provided with several different options for mounting accessories dependent on the actuator configuration.

**Standard Accessory Mounting Example:**

Required items: Actuator, Accessory Arm, Sensor Magnet Array, DVC6200 Positioner, Positioner Mounting Jig.

1. Install positioner or switch mounting bracket.
2. Loosely attach the Magnet Array (if used) to the Accessory Arm.
3. Install the accessory arm or linkage kit on the actuator clamp coupler. Do not tighten the bolts.
4. Install the positioner and secure by inserting bolts through the back of the mounting bracket.
5. Verify proper operation and array or linkage location, then tighten all bolts hand tight plus one quarter turn.
6. For high vibration environments, apply medium strength threadlocker to all threads.

Contact QTRCO for a full listing of available accessory arms or for help with developing a custom mounting kit.

### 1.3 PIPING AND OPERATION

Instrument air, water, and other power gases and fluids such as hydraulic oil may be used to cycle the actuator so long as construction materials were chosen accordingly and max allowable pressure is not exceeded. For hydraulic actuation, QTRCO recommends AMSOIL HVH or equivalent oil. Air driven stainless steel actuators with stainless steel or composite cylinders are not harmed by wet air (so long as freezing does not occur). Aluminum and chrome plated steel cylinders may be harmed over time by the presence of water.

**WARNING**

EXCEEDING THE STATED MAXIMUM PRESSURE MAY RESULT IN DAMAGE TO EQUIPMENT AND DANGER TO PERSONNEL INCLUDING SEVERE INJURY OR DEATH. CONSULT THE ACTUATOR LABEL FOR OPERATING LIMITS. IF AN ACTUATOR LABEL IS MISSING, CONTACT QTRCO TO REQUEST A REPLACEMENT.

**WARNING**

OPERATING OUTSIDE OF THE MINIMUM AND MAXIMUM TEMPERATURE RANGE MAY RESULT IN DAMAGE TO EQUIPMENT AND DANGER TO PERSONNEL INCLUDING SEVERE INJURY OR DEATH. CONSULT THE ACTUATOR LABEL FOR OPERATING LIMITS. IF AN ACTUATOR LABEL IS MISSING, CONTACT QTRCO TO REQUEST A REPLACEMENT. AN EXAMPLE OF AN ACTUATOR LABEL IS PROVIDED BELOW FOR YOUR REFERENCE.

**L-Series Linear Actuator**

Manufactured by:  
**QTRCO® Inc.** - Phone 281-516-0277  
 13120 Theis Ln, Tomball TX 77375, USA

MODEL: **SHORT MODEL #**  
 PART NUMBER: **PART NUMBER**  
 SERIAL NUMBER: **SN** MFG DATE: **99/9999**  
 MAX TRAVEL: **00.000 INCH (000 MILLIMETER)**  
 MATERIALS: **O-RING MATERIAL**  
**MAJOR MOC**  
 MOP P1 (PS): **000 PSI (0 BAR)**  
 MOP P2 (PS): **000 PSI (0 BAR)**  
 TEMP LIMITS (TS): **-00/000 F (-00/000 C)**  
 WEIGHT: **00lb (00kg)**

TAG-L-13C

**II 2 GD c TX**

Maximum surface temperature is dependent on fluids temperature

MANUFACTURER: QTRCO, 13120 Theis Ln, Tomball TX 77375, USA +1 281-516-0277 TAG-ATEX-01

**NOTE:**

CE MARKING INDICATES PRODUCT CONFORMS TO THE REQUIREMENTS OF APPLICABLE DIRECTIVES AS LISTED ON THE ACTUATOR LABEL.

L-Series spring return actuators may be ordered as fail-extend or fail retract. The fail direction is not field reversible

**Fail Extend (Fail Down):** pressure to the base plate port pushes the piston away from the valve, causing the output rod to retract. Springs push the pistons towards the valve causing the output rod to extend

**Fail Retract (Fail Up):** pressure to the end cap port pushes the piston towards the valve, causing the output rod to extend. Springs push the pistons away from the valve causing the output rod to retract.

**Piping guidelines:**

- On fail down models, P2 is a breather port. It must be fitted with a filter or screen to exclude contaminants.
- On fail up models, P1 is a breather port. It must be fitted with a filter or screen to exclude contaminants.
- For outdoor or wash down applications, the breather vent should be orientated to prevent the ingress of water or other fluids. The breather port may also be used to create a closed loop breather system.
- Fail down actuators may be ordered with dual base plate ports for very high speed operation. When provided with two base plate ports (P1), both should be piped together and powered by a single air pathway

**Both Fail up and Fail Down models can be used in a Spring Bias configuration with the spring on one side of the piston and air on both sides of the piston**

Either fail up or fail down models can be converted to spring bias by piping air to both P1 and P2. For spring bias operation the max operating pressure may differ at P1 and P2. Always refer to the actuator label for max operating pressure.

**SPRING BIAS- FAIL UP MODELS**

**P1 – Pressure Port**, pressure and spring retracts the output rod

**P2 – Pressure Port**, pressure extends the output rod

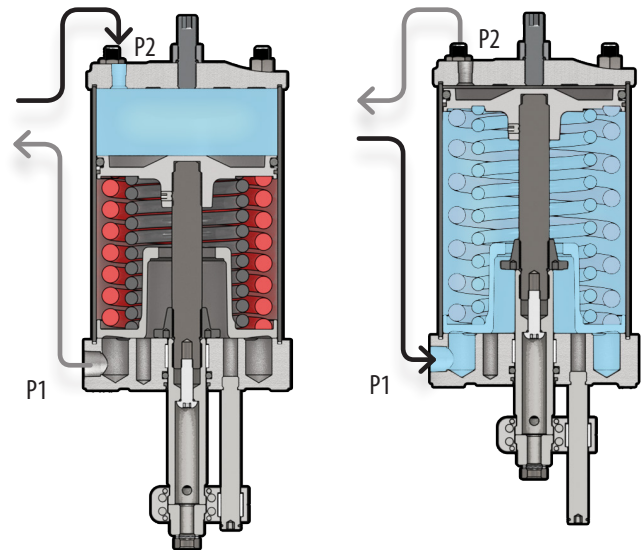

**SPRING BIAS- FAIL DOWN MODELS**

**P1 – Pressure Port**, pressure retracts the output rod

**P2 – Pressure Port**, pressure and spring extends the output rod

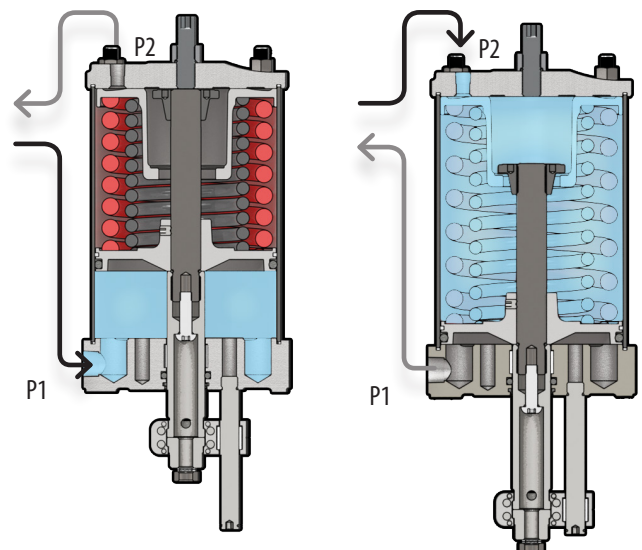

**SPRING RETURN - FAIL UP MODELS**

**P1 – Breather Port**, not used for operation

**P2 – Pressure Port**, pressure extends the output rod

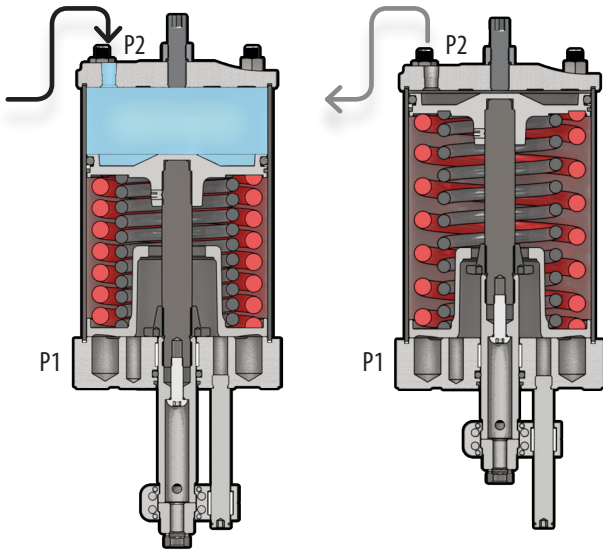

**1.4 TRAVEL ADJUSTMENT**

L-Series actuators have an end cap travel stop that can be used to adjust the retracted position of the output rod. The extended position of the output rod is fixed. The position of the stem adapter should be used to adjust the extended position of the valve. Unless specifically requested, L-Series actuators are adjusted for maximum travel prior to shipment. If proper valve mounting procedures are followed, travel adjustment is usually not necessary. When required valve travel is less than available actuator travel, travel adjustments may be used to change the output thrust applied to the valve.

**WARNING**

TRAVEL ADJUSTMENT MAY REQUIRE MAINTENANCE PERSONNEL TO WORK IN PINCH POINT AREAS. ALWAYS ENSURE THAT HANDS AND TOOLS ARE CLEAR OF THE BRACKET AREA PRIOR TO OPERATING THE ACTUATOR. DO NOT PLACE HANDS OR TOOLS INSIDE THE BRACKET AREA IF THE ACTUATOR IS AT AN INTERMEDIATE TRAVEL POSITION.

**SPRING RETURN - FAIL DOWN MODELS**

**P1 – Pressure Port**, pressure retracts the output rod

**P2 – Breather Port**, not used for operation

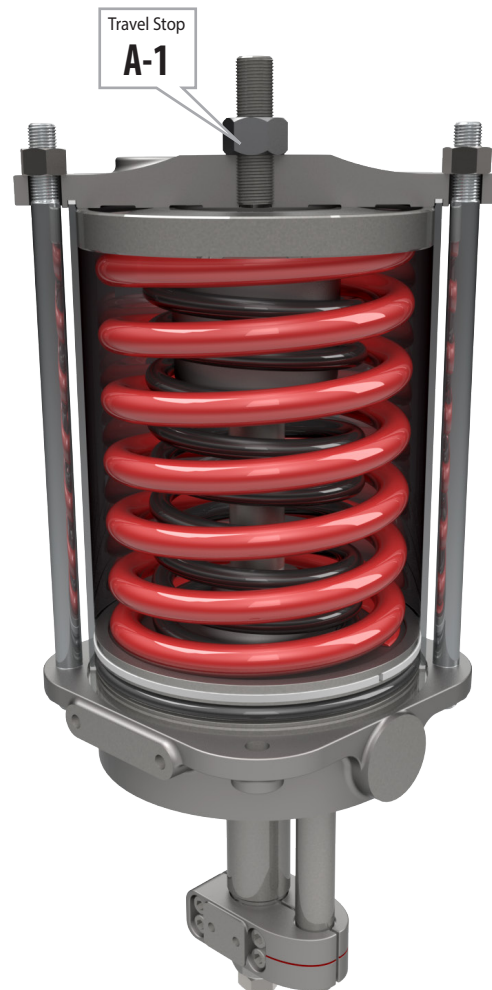
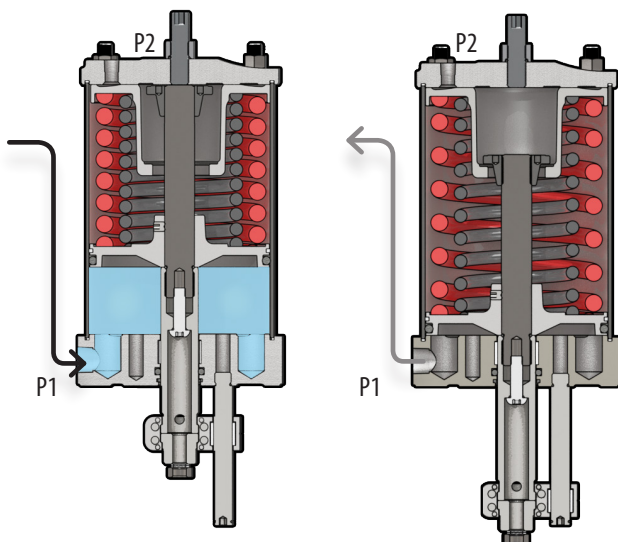



## 1.4 TRAVEL ADJUSTMENT (CONTINUED)

### SET RETRACTED POSITION

#### On fail up models:

- i. Apply pressure to P2
- ii. Loosen the travel stop nut.
- iii. Thread the travel stop inward to reduce overall travel and to set the retracted position closer to the valve.
- iv. Thread the travel stop outward to increase overall travel and to set the retracted position further from the valve.
- v. Exhaust pressure to test travel position. Repeat adjustment if required.
- vi. Tighten the travel stop nut.

#### On fail down models:

- i. Exhaust pressure from P1
- ii. Loosen the travel stop nut.
- iii. Thread the travel stop inward to reduce overall travel and to set the retracted position closer to the valve.
- iv. Thread the travel stop outward to increase overall travel and to set the retracted position further from the valve.
- v. Pressurize P1 to test travel position. Repeat adjustment if required.
- vi. Tighten the travel stop nut.

### SET EXTENDED POSITION

The extended position of the output rod is fixed. The following steps are used to set the extended position of the valve:

#### For Push Down to Close (PDTC) valves:

- i. Remove load from the valve stem by moving the actuator to the retracted position (pressurize P1 on Fail Down models or exhaust P2 on Fail Up models).
- ii. Loosen the stem adapter jam nut
- iii. Loosen the clamp bolts 1 full turn each
- iv. To push the valve into the seat or increase the spring seating force, use an open ended wrench to thread the stem adapter towards the actuator.
- v. To pull the valve out of the seat or decrease the spring seating force, use an open ended wrench to thread the stem adapter away from the actuator.
- vi. Re-tighten the clamp bolts
- vii. Extend the actuator output rod to check the travel position
- viii. Tighten the stem adapter jam nut.

#### For Push Down to Open (PDTO) valves:

- i. Remove load from the valve stem by moving the actuator to the extended position (exhaust P1 on Fail Down models or pressurize P2 on Fail Up models).
- ii. Loosen the stem adapter jam nut
- iii. Loosen the clamp bolts 1 full turn each
- iv. To push the valve into the seat or increase the spring seating force, use an open ended wrench to thread the stem adapter away from the actuator.
- v. To pull the valve out of the seat or decrease the spring seating force, use an open ended wrench to thread the stem adapter towards the actuator.
- vi. Re-tighten the clamp bolts
- vii. Retract the actuator output rod to check the travel position
- viii. Tighten the stem adapter jam nut.



## 2. TROUBLESHOOTING

ISSUE	CAUSE	SOLUTION
Irregular or Stuttering Stroke	Supply pressure too low	Verify operating pressure is correct
	Worn internal components	See Section 3.4-3.5
	Damaged valve	Consult valve manufacturer
	Broken Springs	Replace Springpaq™
Leakage	Damaged cylinder seals	See Section 3.4
	Damaged rod seals	See Section 3.5
	Travel stop nut not tightened.	Tighten travel stop nut.
	Piston o-ring damaged	See Section 3.4
Improper Travel	Travel stop or stem adapter not set correctly	See Section 1.4
	Internal cylinder contaminants preventing normal stroke	See Section 3.4-3.5
	Damaged valve	Consult valve manufacturer
	Insufficient thrust	Upgrade to a larger actuator, increase supply pressure
	Broken Springs	Replace Springpaq™
Operating/Stroking too slowly	Supply pressure too low	Verify operating pressure will produce thrust needed to operate valve correctly
	Internal cylinder contaminants preventing normal stroke	See Section 3.4-3.5
	Damaged or sticky valve	Consult valve manufacturer
	Damaged seals or o-rings causing loss of pressure	See Section 3.4-3.5
	Damaged supply lines	Inspect supply lines and replace as needed
	Breather port is blocked	Inspect port, clean as needed
	Limitation of accessories or port size	Upgrade accessories or port size



### 3. MAINTENANCE

#### 3.1 PERIODIC MAINTENANCE SCHEDULE

General service actuators do not require periodic maintenance. Severe service actuators may require periodic maintenance based on operating conditions. Severe service may include but is not limited to high speed, high cycle, highly corrosive, explosive atmosphere, and others. Special applications may require individual maintenance schedules. Contact QTRCO for help developing a maintenance schedule for your application.

#### 3.2 LUBRICATION

QTRCO actuators are lubricated for life. For special applications grease fittings may be provided. Use the grease fittings (if applicable) incorporated into the actuator to apply additional lubricant. The frequency of this lubrication will depend on the application of the actuator. For any questions regarding the frequency of this operation or appropriate lubrication compounds contact your QTRCO distributor.

**WARNING**

TAKE A MOMENT TO VIEW THE SPRINGPAQ™ IMAGE. NOTE HOW THE SPRINGPAQ™ CANNOT EXPAND WHEN THE END CAP AND CYLINDER ARE REMOVED FROM THE ACTUATOR. THE PISTON AND SPRING RETAINER CONTAIN THE SPRING IN ITS INITIAL COMPRESSED POSITION.

THE SPRING COMPRESSES FURTHER DURING ACTUATOR OPERATION. THE PISTON BOLT EXTENDS FROM THE PISTON TO THE SPRING RETAINER AND IS SECURED BY THE SAFETY COLLAR. THE SAFETY COLLAR IS RECESSED BELOW THE SURFACE OF THE SPRING RETAINER INTENTIONALLY TO PREVENT THE DISASSEMBLY OF THE SPRINGPAQ™.

**DO NOT ATTEMPT TO DISASSEMBLE THE SPRINGPAQ™.**

DISASSEMBLY OF THE SPRINGPAQ™ MAY EXPOSE YOU TO EXTREME DANGER, THE RESULT OF WHICH COULD BE SEVERE INJURY OR DEATH.

THERE IS NO REASON TO TAKE APART A SPRINGPAQ™. IF A SPRING IS BROKEN, REPLACE THE ENTIRE SPRINGPAQ™.

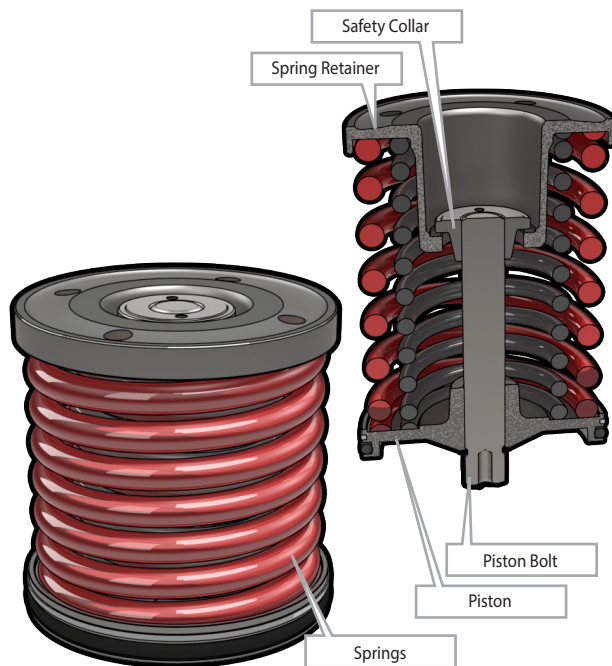

**WARNING**

DO NOT REMOVE/LOOSEN TIE ROD NUTS UNLESS CYLINDER IS FULLY DE-PRESSURIZED  
**COMPONENTS MAY EXIT THE ACTUATOR DANGEROUSLY IF DISASSEMBLY IS ATTEMPTED UNDER PRESSURE.**  
 ENSURE THAT ALL PROCESS LINES ARE SAFE / READ ALL MAINTENANCE INSTRUCTIONS BEFORE STARTING WORK.

**WARNING**

WHEN UNTHREADING TIE ROD NUTS, FIRST UNTHREAD ALL NUTS IN AN ALTERNATING STAR PATTERN UNTIL THEY ARE FLUSH WITH THE ENDS OF THE TIE RODS. IF THERE IS STILL FORCE PUSHING OUTWARD ON THE ENDCAP AT THIS POINT, A DANGEROUS CONDITION MAY EXIST. A TRAVEL STOP OR OVERRIDE DEVICE MAY BE PUTTING PRESSURE ON THE SPRINGS, OR THERE MAY BE COMPONENT DAMAGE. FULLY REMOVING THE TIE ROD NUTS IN THIS CONDITION MAY ALLOW THE SPRINGS TO DANGEROUSLY DECOMPRESS.

DO NOT CONTINUE FURTHER UNTIL IT IS ASSURED THAT THE UNIT IS SAFE TO DISASSEMBLE.



**NOTE:**

FOR FAIL-UP (RETRACT) ACTUATORS, THE TRAVEL STOPS MUST BE FULLY UNTHREADED PRIOR TO REMOVING THE END CAP. LEAVING THE TRAVEL STOPS IN PLACE WILL PUT SPRING PRESSURE ON THE END CAP WHEN IT IS REMOVED, WHICH COULD CAUSE SERIOUS INJURY OR DEATH.

**3.3 MAINTENANCE KIT**

To purchase your actuator maintenance kit contact your QTRCO distributor. Please have the serial number of your actuator available. This number may be found on the actuator label or stamped into the body of the actuator.

**3.4 PISTON O-RING REPLACEMENT**

1. Exhaust all pressure and disconnect all supply lines.
2. Loosen all tie rod nuts until they are flush with the ends of the tie rods.
3. Check that there is no pressure against the end cap by verifying that the end cap is not being forced against the tie rod nuts.

**WARNING** IF THERE IS FORCE AGAINST THE END CAP, STOP. DO NOT CONTINUE FURTHER UNTIL IT IS ASSURED THAT THE UNIT IS SAFE TO DISASSEMBLE.

4. Remove the end cap. Be careful not to lose the cylinder seal located on the internal side of the end cap.

5. Remove the cylinder. Be careful not to damage the internal surface of the cylinder as this will compromise the piston's ability to seal.
6. Replace the piston o-ring and wiper ring as needed. Be sure to lubricate the new o-ring and wiper ring with the correct QTRCO approved lubricant if they are replaced.

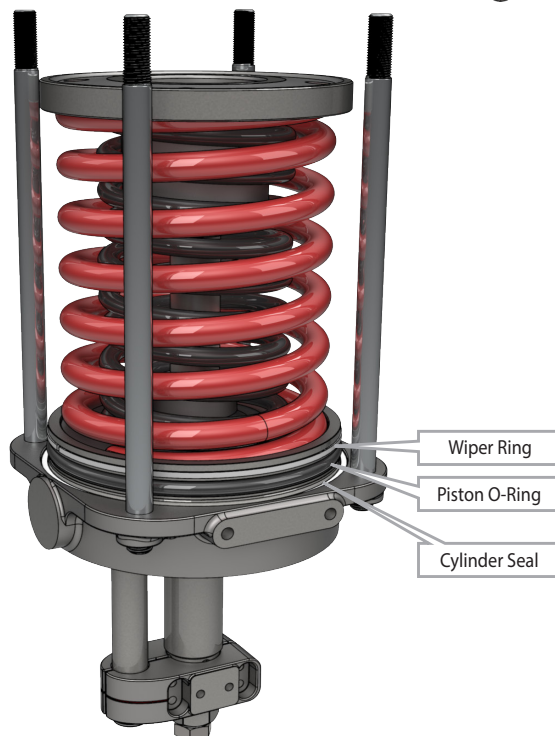
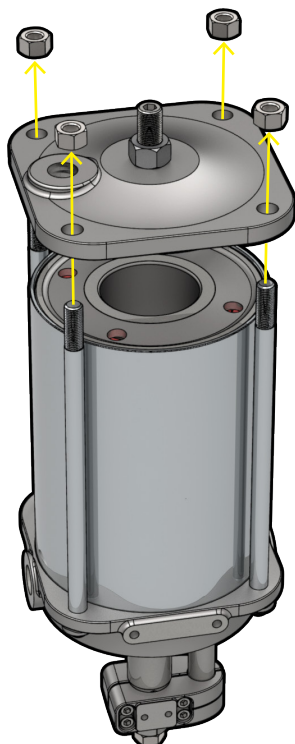
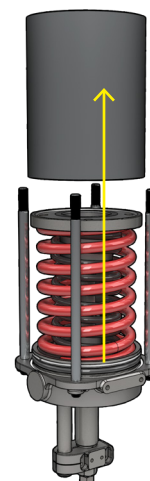

7. Inspect the piston for any corrosion or wear (pitting, cracking). If excessive corrosion or wear is apparent a new actuator or actuator components may be necessary.
8. Lubricate the internal surface of the cylinder with a light coat of the correct QTRCO approved lubricant and slide the cylinder back over the piston and into the cylinder seal groove of the base plate, taking care not to pinch the piston o-ring.
9. Place the end cap back over the tie rods. Be sure that the cylinder is seated in the cylinder seal groove of the end cap with the cylinder seal still in place between the cylinder and the end cap.
10. Secure the end cap with the tie rod hex nuts removed in step two. Hand tighten, and then torque the hex nuts to half and then full values according to the table below using the pattern designated.

MODEL	LB* FT	Nm
L04	10	14
L06	20	27
L08	35	48
L10	35	48
L12	35	48
L14	56	76
L16	56	76
L20	58	79
L24	87	118

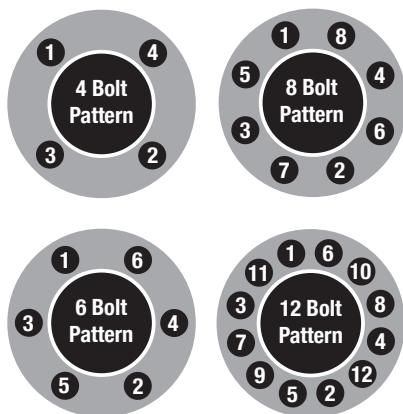

11. Reset the travel stop
12. Leak Test
13. Reinststate the actuator to service

### 3.5 ROD SEAL AND BUSHING REPLACEMENT

1. Ensure the valve stem is unloaded.
2. Decouple the actuator from the valve by removing the clamp coupler.
3. Follow Section 3.4, Steps 1-5.
4. Lift the springpaq straight up and out of the base plate
5. Remove the rod bushing, o-ring, and wiper ring

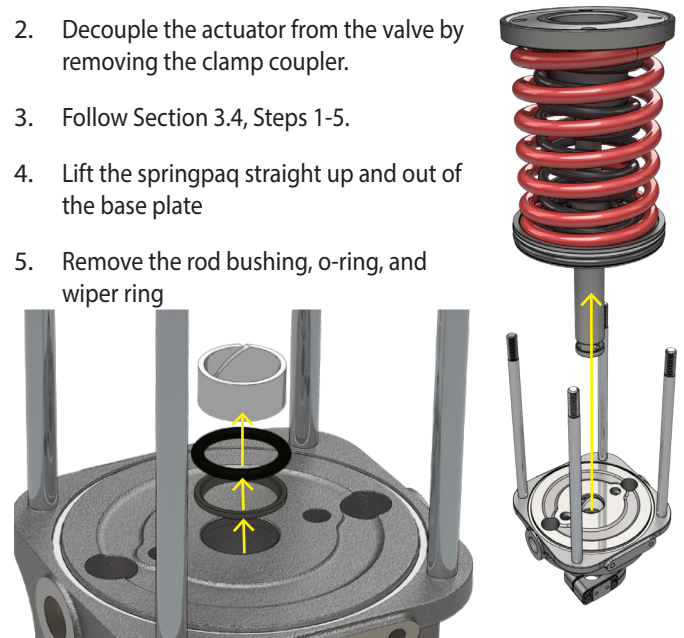

6. Clean the bushing and o-ring grooves of any contaminants.
7. Replace the rod bushing, o-ring, and wiper ring
8. Fill the remaining space in the grooves with the proper QTRCO approved lubricant.
9. Clean the output rod, inspect for wear or damage, and replace if necessary.
10. Lower the springpaq back into the baseplate.
11. Lubricate the internal surface of the cylinder with a light coat of the correct QTRCO approved lubricant and slide the cylinder back over the piston and into the cylinder seal groove of the base plate, taking care not to pinch the piston o-ring.
12. Place the end cap back over the tie rods. Be sure that the cylinder is seated in the cylinder seal groove of the end cap with the cylinder seal still in place between the cylinder and the end cap.

- Secure the end cap with the tie rod hex nuts removed in step two. Hand tighten, and then torque the hex nuts to half and then full values according to the table below using the pattern designated.

MODEL	LB* FT	Nm
L04	10	14
L06	20	27
L08	35	48
L10	35	48
L12	35	48
L14	56	76
L16	56	76
L20	58	79
L24	87	118

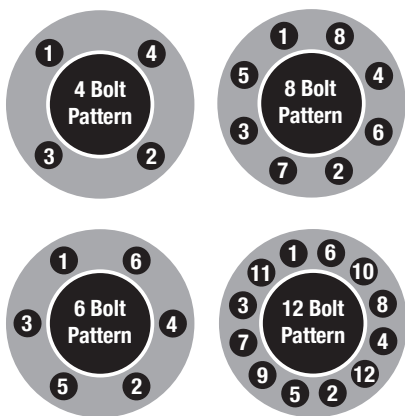

- Reset the travel stop
- Leak Test
- Reinstate the actuator to service

### 3.6 OUTPUT ROD REPLACEMENT

If the seal rod has wear, scratches, or damage that may cause rod seal leakage, it should be replaced. The seal rod is threaded onto the piston bolt and secured using a combination of thread locker and a lock bolt installed inside of the seal rod.

- Remove the actuator from the valve.
- Unthread the output rod lock bolt.
- Insert a tool into the cross-hole in the output rod to unthread it from the piston bolt and remove it from the actuator.
- Replacement of the o-rings between the output rod and piston and lock bolt and the seal rod is highly recommended, but not required if the o-rings are in good condition.
- Installation is reverse of removal. Apply medium strength thread-locker to the female threads of the new output rod and to the lock bolt prior to reassembly.
- Reinstall the lock bolt and torque to the values in the table below:

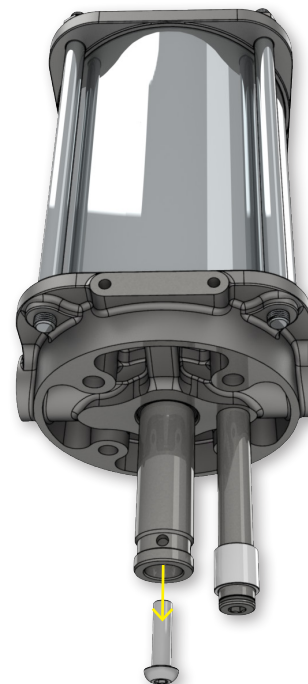

	Thread Size	Hex Drive Size	Ft-Lbs	Nm
L04	M8-1.25	5 mm	13	18
L06	M10-1.5	6 mm	26	35
L08	M12-1.75	8 mm	45	61
L10	M14-2.0	10 mm	58	78
L12	M16-2.0	12 mm	90	122
L14	M16-2.0	12 mm	90	122
L16	M20-2.0	17 mm	138	187
L20	M24-3.0	19 mm	200	271
L24	M30-3.5	22 mm	300	407

## 4. APPENDIX

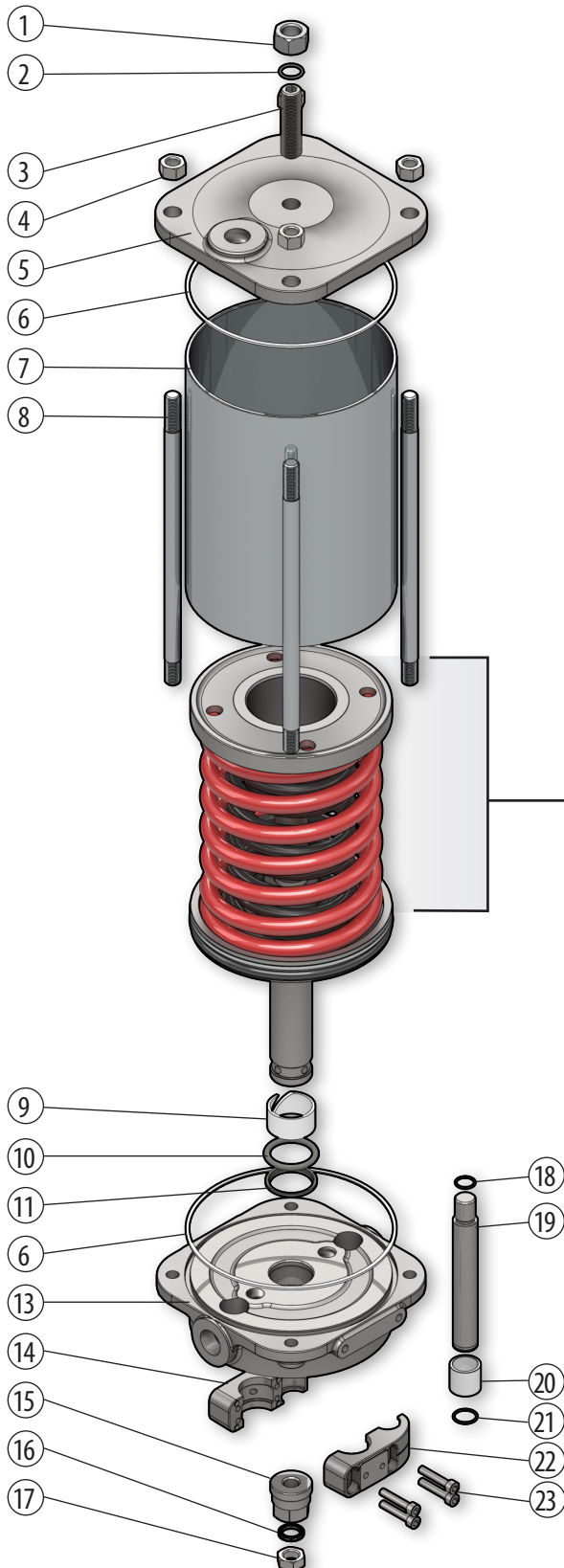

No.	Part Description	Material
1	Travel Stop Nut	316 SST
2	Travel Stop O-Ring	Option*
3	Travel Stop	316 SST
4	Tie Rod Nut	316 SST
5	End Cap	CF8M (316 SST)
6	Cylinder Seal	PTFE*
7	Cylinder	316 SST
8	Tie Rod	316 SST

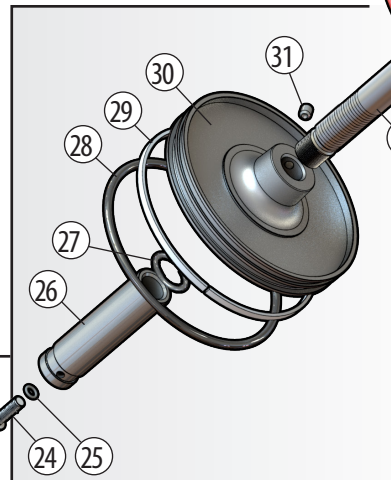

No.	Part Description	Material
9	Rod Bushing	Carbon/Graphite PTFE*
10	Rod Seal	Option*
11	Rod Wiper	Option*
12	Clamp Coupler Side A	CF8M (316 SST)
13	Baseplate	CF8M (316 SST)
14	Stem Adapter	316 SST
15	Wedge Lock Washer	316 SST
16	Stem Locknut	316 SST
17	Pin O-Ring	Option*
18	Anti-Rotate Pin	17-4 PH SST
19	Anti-Rotate Bushing	Carbon/Graphite PTFE*
20	Retaining O-Ring (for assembly only)	Option*
21	Clamp Coupler Side B	CF8M (316 SST)
22	Clamp Bolts	316 SST

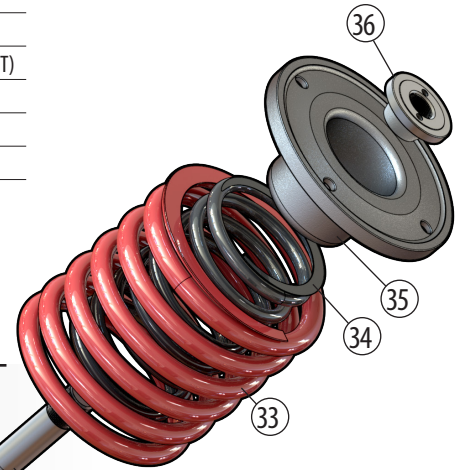

### SPRINGPAQ™

No.	Part Description	Material
23	Output Rod Lock Bolt	316 SST
24	Lock Bolt O-Ring	Option*
25	Output Rod	17-4 PH SST
26	Piston Bolt O-Ring	Option*
27	Piston O-Ring	Option*
28	Piston Wiper Ring	PTFE*
29	Piston	CF8M (316 SST)
30	Piston Set Screw	17-4 PH SST
31	Piston Bolt	316 SST
32	Outer Spring	Option*
33	Inner Spring	Option*
34	Spring Retainer	CF8M (316 SST)
35	Safety Collar	316 SST

Parts 32 through 35 are exclusive to spring return actuators.

\* Materials may be modified per application requirements. See engineering string for details.



**The Leader in Actuator Technology**

---

**QTRCO, Inc.** | phone (281) 516-0277  
13120 Theis Lane • Tomball, TX 77375 USA

**QTRCO-SG** C/O Severn Glocon FZE | phone +971 (0) 4 880 7330  
Unit HC06, RA08 • North Zone, Jebel Ali Freezone UAE

 **888.ACTU.8.IT**  
888.228.8848

 **www.qtrco.com**  
Email: actu8it@qtrco.com