

I O M
INSTALL-OPERATE-MAINTAIN

HYDRAULIC OVERRIDE

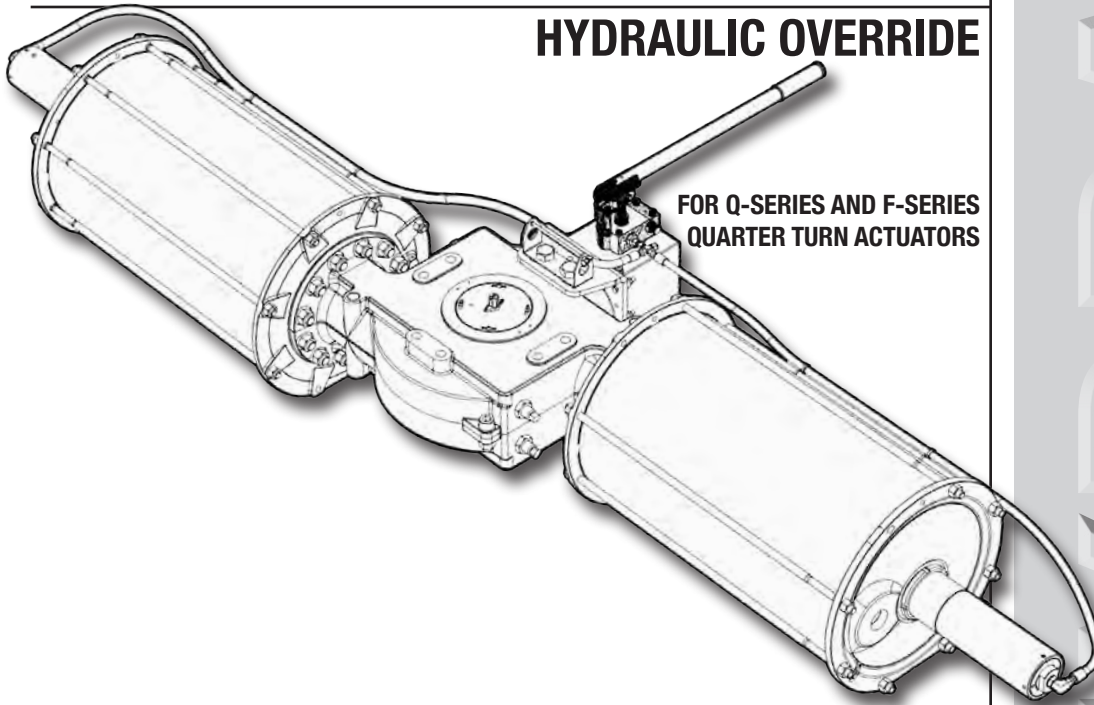

FOR Q-SERIES AND F-SERIES
QUARTER TURN ACTUATORS

HYDRAULIC
OVERRIDE



The Leader in Actuator Technology



NOTE:

ALL ACTIVITIES MUST BE CARRIED OUT IN ORDER TO ENSURE PROPER ACTUATOR OPERATION.
ALWAYS READ ALL INSTRUCTIONS BEFORE BEGINNING MAINTENANCE.

Contact QTRCO with any questions at info@qtrco.com or 281-516-0277.

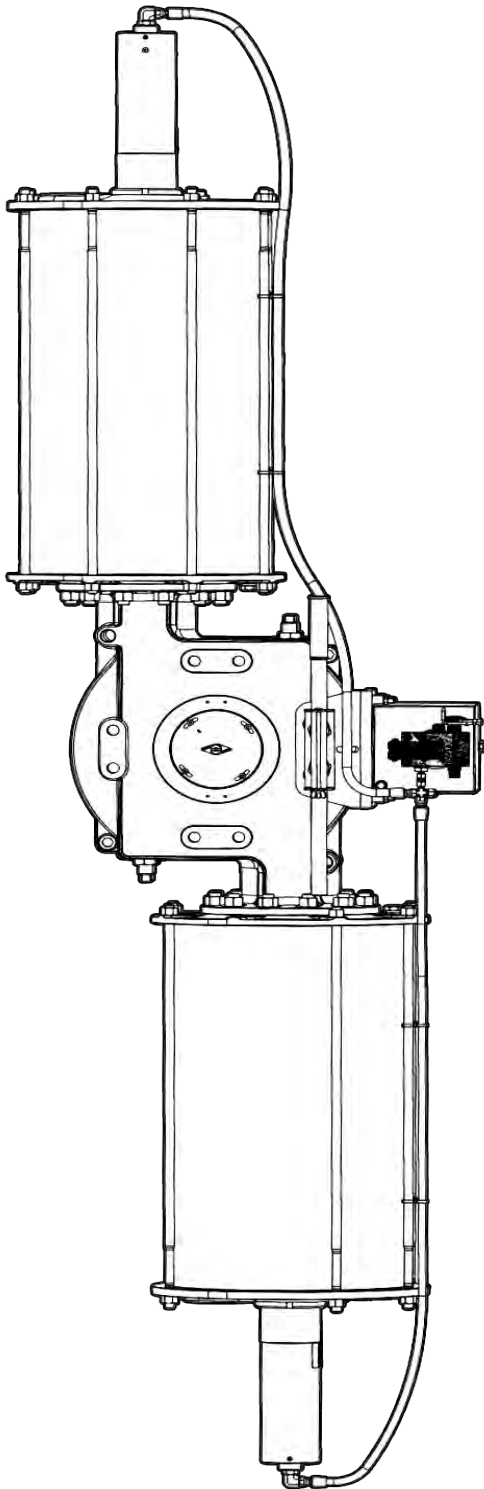

CONTENTS

1. INSTALLATION	4
1.1 PIPING AND OPERATION	5
1.2 TRAVEL ADJUSTMENT	7
2. TROUBLESHOOTING	8
3. MAINTENANCE	9
3.1 PERIODIC MAINTENANCE SCHEDULE	9
3.2 LUBRICATION	9
3.3 MAINTENANCE INTERVALS	9
3.4 PISTON AND END CAP SEAL REPLACEMENT	9
3.5 BLOCK PLATE WIPER REPLACEMENT	10
3.6 BLOCK PLATE CHECK VALVE ADJUSTMENT	11
3.7 FLUID MANAGEMENT	12
3.8 BLEEDING THE SYSTEM	12
3.9 PRESSURE RELIEF VALVE ADJUSTMENT	13
3.10 LEAK TEST	14
3.10 FUNCTIONAL TEST	14
3.11 PUMP CONTROL KNOB LOCKOUT	14
3.12 PUMP CONTROL KNOB LOCKOUT	14
4. APPENDIX	15

1. INSTALLATION

QTRCO actuators may be mounted in any position/orientation. If necessary, lift the actuator with straps placed inside the framework of the body. **NEVER lift the actuator by the cylinders, tie rods, or travel stops.** Lifting the actuator with the valve attached is not generally recommended.

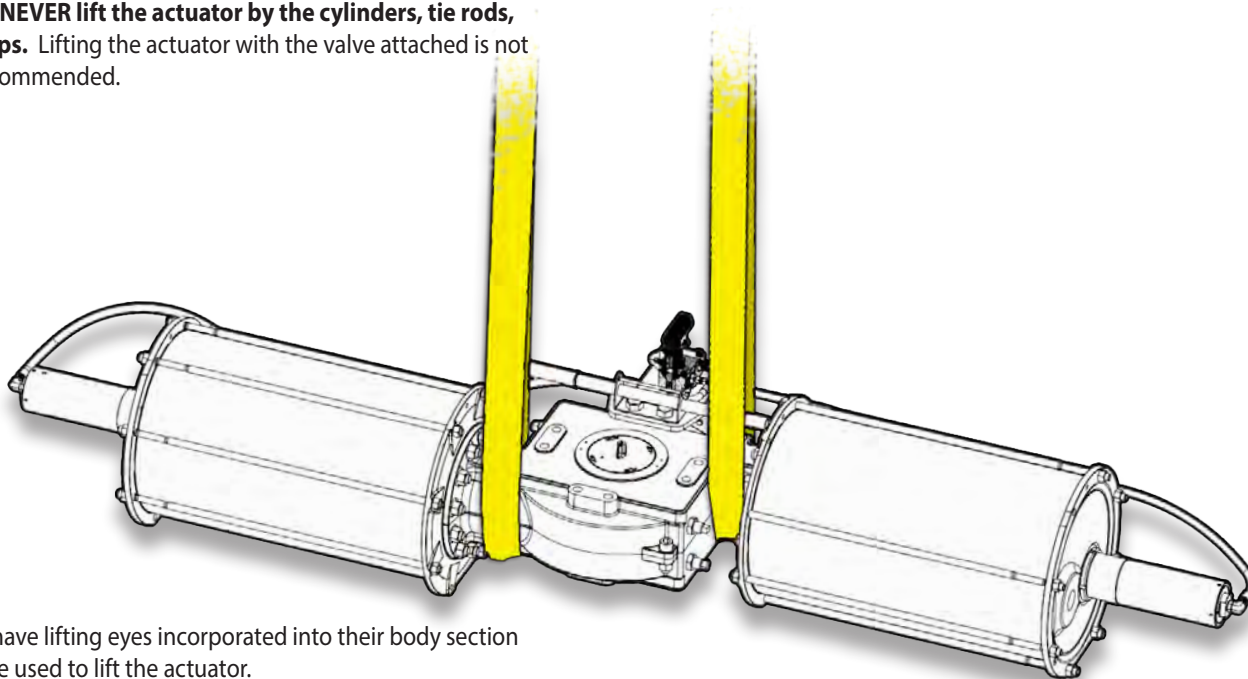

Larger sizes have lifting eyes incorporated into their body section which may be used to lift the actuator.

Actuators with Hydraulic Overrides must never be lifted by the hydraulic cylinders. Always ensure that lifting straps do not crush hydraulic tubing or hose. After actuator installation, always verify that hydraulic hose/tubing is not cut, worn, kinked, crushed, or excessively bound.

Always refer to mounting instructions in the actuator instructions.

For actuators with a manual hand pump and reservoir attached:

When a manual hand pump is used with an attached reservoir, the reservoir must always be mounted so that the reservoir vent faces up with respect to gravity. Actuators with pump/reservoir attached will be shipped in a configuration suitable for normal horizontal orientation. To avoid spills, pump/reservoir orientation should only be modified when the reservoir is empty.

After the actuator is tested at the factory, the reservoir is emptied into separate containers in preparation for shipping. The container(s) are filled and shipped with the actuator.

After the actuator is securely mounted, remove the vent cap and use the provided funnel to fill the reservoir with the provided fluid. Fill the reservoir between 80% and 90% of full, leaving 10% to 20% air space. The volume of proper fill is marked on the reservoir tag.

It is normal for extra fluid to remain in the container(s) when the reservoir is full. This excess fluid may be used to replenish fluid lost to leaks or spills.

Do not overfill the reservoir.

Due to turbulent flow in an over-filled reservoir, some fluid may exit the vent port when the fluid returns to the reservoir at high speed. This condition is normal in an overfilled reservoir and the fluid that exits the vent port does not need to be replaced.

Reinstall the vent cap. Tighten hand tight plus $\frac{1}{4}$ turn. The system has been bled of air at the factory. It is not normally necessary to re-bleed the system.

Storage

Depressurize and drain the system prior to decommissioning or storage. Always dispose of used fluid in accordance with local laws and procedures. When not in use, pump handles should not be left attached to the pump. Store the pump handle by using the provided storage bracket.



1.1 PIPING AND OPERATION

The QTRCO Hydraulic Override is operated by high pressure hydraulic fluid. Fluid is pumped, either by hand pump or hydraulic power source, into hydraulic cylinders mounted to the actuator end caps. Fluid pressurizes the hydraulic cylinder and forces the piston and piston rod to move towards the actuator axis, pushing on the actuator's primary piston. When hydraulic fluid pressure is relieved, the actuator springs (or pressure behind the actuator piston for double acting models), force the fluid to return to the fluid reservoir. The system is designed for ISO 32 or equivalent hydraulic fluid. QTRCO can provide synthetic, biodegradable, food-grade, or other oil types on request

WARNING

HYDRAULIC OVERRIDE SYSTEMS ARE NOT SAFETY DEVICES. DO NOT ATTEMPT INSPECTIONS OR REPAIRS ON MOVING VALVE OR ACTUATOR COMPONENTS WHILE RELYING ON THE HYDRAULIC OVERRIDE TO MAINTAIN VALVE POSITION. THE HYDRAULIC OVERRIDE IS SUSCEPTIBLE TO SIMILAR FAILURE MODES AS THE PRIMARY PNEUMATIC ACTUATOR, SUCH AS LEAKAGE, SUPPLY PRESSURE LOSS, LINE AND FITTING DAMAGE, AND ACCIDENTAL OR IMPROPER OPERATION. NEVER PLACE BODY PARTS OR TOOLS INSIDE OF A VALVE WHILE RELYING ON THE HYDRAULIC OVERRIDE TO HOLD VALVE POSITION.

IF USING THE PRIMARY ACTUATOR IN A SAFETY CRITICAL SYSTEM, THE HYDRAULIC OVERRIDE MUST ALWAYS BE DEENERGIZED AND LOCKED OUT UNLESS THE PIPELINE AND RELATED SYSTEMS ARE IN A SAFE STATE. FAILURE TO FOLLOW THIS GUIDANCE MAY PREVENT THE ACTUATOR FROM PERFORMING THE INTENDED SAFETY FUNCTION, AND INVALIDATES ANY SAFETY INTEGRITY LEVEL DATA.

WARNING

EXCEEDING THE STATED MAXIMUM PRESSURE MAY RESULT IN DAMAGE TO EQUIPMENT AND DANGER TO PERSONNEL INCLUDING SEVERE INJURY OR DEATH. CONSULT THE ACTUATOR LABEL FOR OPERATING LIMITS. IF AN ACTUATOR LABEL IS MISSING, CONTACT QTRCO TO REQUEST A REPLACEMENT.

NOTE:

CE MARKING INDICATES PRODUCT CONFORMS TO THE REQUIREMENTS OF APPLICABLE DIRECTIVES AS LISTED ON THE ACTUATOR LABELS.

WARNING

OPERATING OUTSIDE OF THE MINIMUM AND MAXIMUM TEMPERATURE RANGE MAY RESULT IN DAMAGE TO EQUIPMENT AND DANGER TO PERSONNEL INCLUDING SEVERE INJURY OR DEATH. CONSULT THE ACTUATOR LABEL FOR OPERATING LIMITS. IF AN ACTUATOR LABEL IS MISSING, CONTACT QTRCO TO REQUEST A REPLACEMENT. EXAMPLES OF ACTUATOR LABELING ARE PROVIDED BELOW FOR YOUR REFERENCE.

MODEL: SHORT MODEL # PART NUMBER: PART NUMBER SERIAL NUMBER: SN MFG DATE: 99/9999 MATERIALS: MAJOR MOC / SEAL MATERIAL MOP (PSI): 207 BAR (3000PSI) TEMP LIMITS (TS): -/+C, -/+F VOLUME: x LITERS CYLINDER BORE: x MM / x INCH OIL TYPE: x	TAG-HR-16
---	---

QTRCO: 281-516-0277, 13120 THEIS LN, TOMBALL TX 77375 USA

- To operate with provided hand pump:**
1. Remove the pump lever from the storage bracket by loosening the wing nut several turns.
 2. Re-tighten the wing nut to prevent loss.
 3. Loosen the screw in the pump lever bracket on top of the pump assembly to allow lever installation.
 4. Insert the pump lever into the pump lever bracket.
 5. Tighten the pump lever bracket screw in to engage the indentation in the pump lever.
 6. Remove the pump control knob lockout, if installed.
 7. Turn the pump control knob fully clockwise until tight.
 8. Raise and lower the lever until the actuator reaches the desired position. Pressurized fluid flows with both the up and down stroke.
 9. If the pump lever becomes very difficult to move and the actuator does not rotate, stop pumping. Either the actuator has reached the end of travel or there may be another system issue that must be investigated.
 10. If the actuator is left in a static position with the hydraulic cylinders engaged, the actuator position must be checked periodically to ensure no movement occurs due to undetected system leaks. Begin with checks every few minutes. The inspection interval may be increased over time.
 11. To relieve pressure, slowly turn the pump control knob counter clockwise until the actuator starts to move. Always relieve pressure at the slowest acceptable rate.



12. Once the actuator has moved to the fully stroked position, rotate the pump control knob counterclockwise until the lockout can be reinstalled.
13. Install the lockout and secure in accordance with local procedures.
14. Loosen the pump lever bracket screw and remove the pump handle.
15. Re-tighten the screw to prevent loss.
16. Loosen the wing-nut on the pump storage bracket.
17. Return the pump lever to the storage bracket and tighten the wing-nut until the pump lever cannot be removed from the bracket.

NOTE:

THE MOST COMMON LOCATION OF NON-VISIBLE LEAKAGE IS BACK THROUGH THE PUMP VALVE. IF UNDESIRABLE ACTUATOR MOVEMENT OR DE-PRESSURIZATION OCCURS, ALWAYS CHECK THE PUMP CONTROL KNOB FIRST TO ENSURE THAT IT IS FULLY ENGAGED. IN APPLICATIONS WHERE THE CYLINDERS MUST REMAIN PRESSURIZED FOR EXTENDED PERIODS OF TIME, AN ISOLATION VALVE MAY BE INSTALLED BETWEEN THE PUMP AND HYDRAULIC LINES TO MAXIMIZE HOLDING TIME.

Piping guidelines:

- Pneumatic actuator piping must follow the guidelines in the relevant actuator instructions
- For dual cylinder models, hydraulic hose must be connected to both P7 and P8 and powered by a single pathway.

Normal Operation (Open):

- Pneumatic pressure engaged
- Hydraulic pressure disengaged

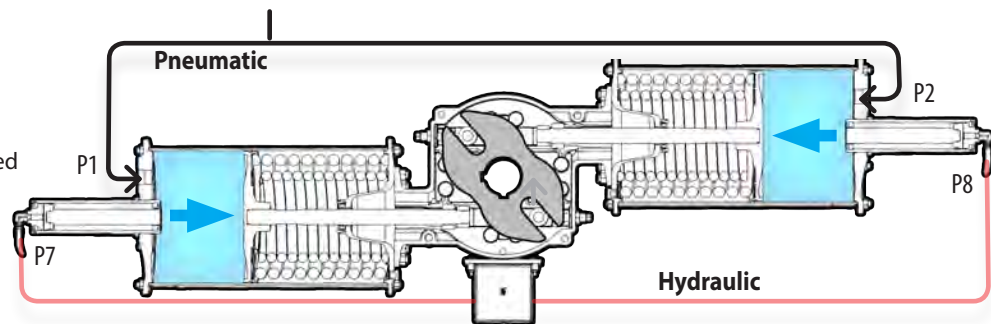

Normal Operation (Fail Closed):

- Pneumatic pressure disengaged
- Hydraulic pressure disengaged

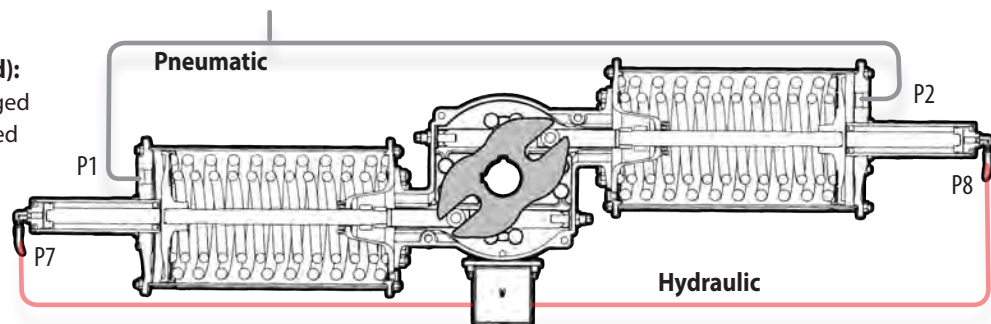

Hydraulic Override (Open):

- Pneumatic pressure disengaged
- Hydraulic pressure engaged

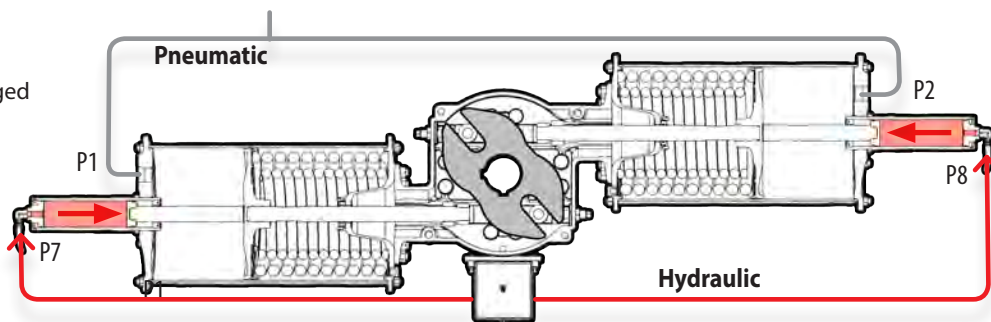

1.2 TRAVEL ADJUSTMENT

To change body side travel stops, refer to the actuator specific instructions. On actuators with a QTRCO hydraulic override, the hydraulic cylinder may be threaded in and out of the actuator end cap to facilitate travel adjustment. The end cap of the hydraulic cylinder swivels to allow travel adjustment without loosening hydraulic fittings.

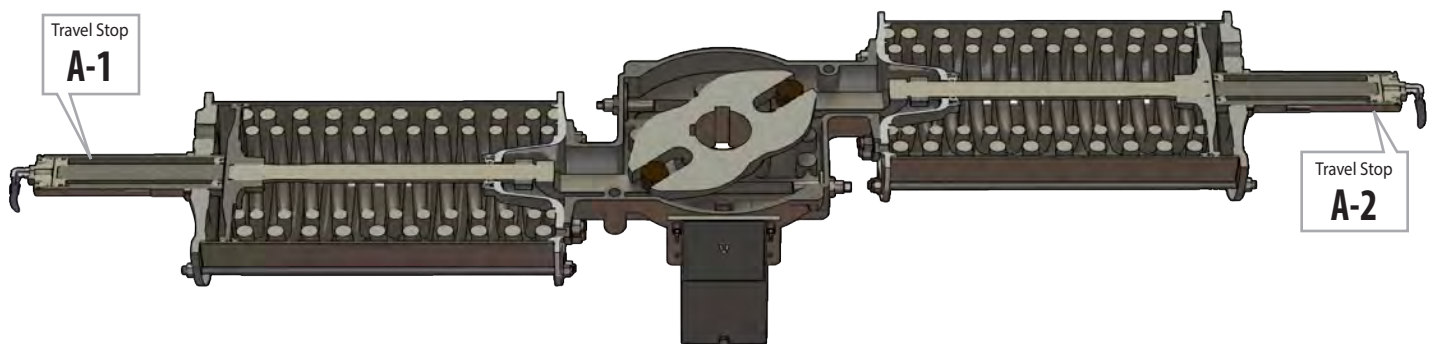

SET ENDCAP TRAVEL (CCW travel on LH actuators, CW travel on RH actuators)

1. Relieve all pressure from the actuator and hydraulic system
2. Loosen the spanner nut around the hydraulic cylinder, taking care not to damage the cylinder threads. Be careful not to misplace the spanner nut o-rings.
3. Ensure actuator lockout (if provided) is disengaged
4. Apply low pressure air to P1 and P2. Only apply enough pressure to move the actuator to the desired travel position. If adjusting for increased travel, pressure must still be applied until the actuator moves slightly to ensure load is removed from the hydraulic cylinders.
5. If adjusting for increased travel on dual cylinder models, unthread cylinder A-2 four full turns.
6. Adjust cylinder A-1 until travel is set to the desired position. For spring return units, it may be necessary to relieve pressure from P1 and P2 between adjustments to determine final position of travel. For double acting units, this may require applying low pressure air to P3 and P4.
7. For spring return units, relieve air pressure. For double acting units, apply pressure to the actuator base plates (P3 and P4).
8. Thread cylinder A-2 inward until it makes firm contact with the second piston.
9. Double check travel.
10. Tighten spanner nut(s) until they make contact with the actuator end cap(s), then tighten an additional ¼ turn.
11. Pressurize P1 and P2, check for leaks around the spanner nuts and hydraulic cylinder threads.



2. TROUBLESHOOTING

GENERAL TROUBLESHOOTING

NOTE:

THESE TROUBLESHOOTING STEPS APPLY TO CONDITIONS THAT AFFECT THE HYDRAULIC OVERRIDE AND ASSOCIATED CONTROLS. FOR GENERAL ACTUATOR TROUBLESHOOTING STEPS, REFER TO THE ACTUATOR SPECIFIC INSTRUCTIONS.

ISSUE	CAUSE	SOLUTION
Hydraulic override fails to stroke fully while pump handle is easy to move or while hydraulic pressure remains low.	Pump control knob not fully engaged	Engage pump control knob
	Low fluid	Refill system (Section 1)
	Leakage	Inspect for leaks (3.9)
	Improperly set or damaged pressure relief valve	Inspect and adjust pressure relief valve.
Hydraulic cylinders behave erratically, stutter or stick intermittently, or reverse direction unprompted.	Excessive air in system	Bleed air from system (Section 3.8)
	Leakage	Inspect for leaks (3.9)
	Hydraulic system contamination	Drain, clean, and refill system (Section 1)
	Component Damage	Inspect system for component damage
	Actuator or Valve Damage	Inspect actuator and valve
Hydraulic override fails to stroke fully while handle is very difficult to move or while hydraulic pressure is high.	Hydraulic system contamination	Drain, clean, and refill system (Section 1)
	Hose or tubing damage	Inspect hose and tubing (both pneumatic and hydraulic)
	Improper actuator or valve travel	Consult actuator or valve instructions
	Component damage	Inspect system for component damage
	Actuator or Valve Damage	Inspect actuator and valve
Actuator does not return to fail safe (spring return) or piston fully outward position.	Pump control knob not disengaged	Disengage pump control knob
	Hydraulic system contamination	Drain, clean, and refill system (Section 1)
	Hose or tubing damage	Inspect hose and tubing (both pneumatic and hydraulic)
	Improper actuator or valve travel	Consult actuator or valve instructions
	Component damage	Inspect system for component damage
	Actuator or Valve Damage	Inspect actuator and valve
Hydraulic override operates correctly, but pressure relieves slowly over time.	Leakage	Inspect for leaks (3.9)
	Pump control knob not fully engaged	Engage pump control knob
	Pump bypass failure	Replace pump Install isolation valve between pump and system

*Clockwise rotation of travel stops will shorten actuator stroke (stroke < 90°), counterclockwise rotation will lengthen actuator stroke (stroke > 90°).



3. MAINTENANCE

NOTE:

ALWAYS ENSURE HYDRAULIC CYLINDER COMPONENT THREADS ARE CLEAN AND UNDAMAGED PRIOR TO REASSEMBLY. THREADS THAT DO NOT REQUIRE THREAD LOCKER SHOULD BE OILED OR GREASED TO ENSURE SMOOTH OPERATION AND TO PREVENT SEIZING ON REASSEMBLY.

3.1 PERIODIC MAINTENANCE SCHEDULE

General service actuators do not require periodic maintenance. Severe service actuators may require periodic maintenance based on operating conditions. Severe service may include but is not limited to high speed, high cycle, highly corrosive or explosive atmosphere, and other conditions. Special applications may require individual maintenance schedules. Contact QTRCO for help developing a maintenance schedule for your application.

3.2 LUBRICATION

On assemblies operating with QTRCO approved hydraulic fluid, the fluid provides component lubrication. While not usually necessary, the pump handle linkage may be lubricated with NLGI grade 2 lithium based grease or equivalent.

NOTE:

NOTE: ALL ACTIVITIES MUST BE CARRIED OUT IN ORDER TO ENSURE PROPER ACTUATOR OPERATION. ALWAYS READ ALL INSTRUCTIONS BEFORE BEGINNING MAINTENANCE. WHEN MAINTENANCE STEPS REQUIRE THE DISASSEMBLY OF MAIN ACTUATOR COMPONENTS, ALWAYS FULLY READ AND UNDERSTAND THE ACTUATOR SPECIFIC MAINTENANCE AND SAFETY INSTRUCTIONS PRIOR TO PROCEEDING.

3.3 MAINTENANCE INTERVALS:

When used only as a manual override with hand pump, periodic maintenance is not required. Disassembly only needs to be performed if the system fails to operate correctly and if disassembly and maintenance will rectify the issue.

When used as a primary operator with external hydraulic power supply, maintenance is required on an as needed basis dependent on the application. Periodic leak tests, functional tests, and fluid analysis should be undertaken out to preempt potential issues.

3.4 PISTON AND END CAP SEAL REPLACEMENT

1. Relieve all pressure from the actuator and hydraulic system.
2. This procedure may be accomplished without disconnecting hydraulic supply lines. If hydraulic lines are not disconnected, always support all removed components to prevent accidental drops and line damage. Always protect component threads from damage that could prevent reassembly.
3. Remove the set screws from the sides of the hydraulic cylinder.
4. While using a spanner wrench in the unthreaded holes on the outside of the cylinder to prevent cylinder rotation, use a second spanner wrench to unthread the hydraulic endcap ring.
5. Remove the endcap ring and endcap.
6. Thread M8-1.25 bolts or threaded rods into the threaded holes now visible in the hydraulic piston and pull to remove. Use the M8-1.25 bolts or threaded rod to maintain alignment so that the piston and rod do not cant, which may scratch the cylinder wall.
7. Replace the o-rings and backup rings on the endcap and piston with new parts from the maintenance kit. The backup ring must always go to the outside of the pressurize area, such that hydraulic fluid contacts the o-ring but not the backup ring. On most models, the backup ring has a concave surface in one side. The backup ring must be installed so that the o-ring is cradled in that surface. The piston backup ring must be on the rod side of the groove. The endcap backup ring must be installed on the outer side of the groove, closest to the threaded opening of the fluid port.
8. Replace the piston wiper ring.
9. Lightly coat the o-rings, backup rings, and piston wiper ring with hydraulic oil.
10. Inspect the inside of the cylinder for contaminants and damage. If contaminants are present, carefully wipe the cylinder wall with a lint-free cloth. If the cylinder wall is visibly damaged, it may need to be replaced. While inspecting the cylinder, notice the hole in the block plate on the opposite end of the cylinder. The piston rod must be inserted into that hole on reassembly.



11. Reinsert the piston, rod end first. Use the M8-1.25 bolts or threaded rod to keep the piston properly aligned, and to maneuver the rod through the hole in block plate.
12. Push the piston inward until it moves fully beyond the threaded area inside of the cylinder.
13. Insert the endcap. This may require threading the endcap into place to overcome interference cause by the backup ring.
14. Thread the endcap ring into the cylinder until the point of refusal, but do not tighten. Unthread the endcap ring up to one-half turn until the grooves on the outside of the endcap ring align with the threaded cross holes in the cylinder. The exposed face of the endcap ring should sit flush with or below the end of the cylinder..
15. Apply medium strength thread locker to the endcap ring set screws. Install the set screws loosely and ensure that the set screws are in the endcap ring grooves and not contacting the endcap ring threads. Failure to adhere to this step may prevent future disassembly and maintenance.
16. Torque the set screws to the values in the table below:

Hydraulic Cylinder Bore Size (inch)	Set Screw Size	Hex Drive Size	Torque ftlb (Nm)
2.0	M6-1.0	3mm	3.5 (4.7)
2.5-3.25	M8-1.25	4mm	12 (16)
4.0-4.75	M10-1.5	5mm	19 (26)

17. The endcap should rotate without significant effort, and may move in and out of the cylinder slightly. This behavior is normal and allows adjustment of travel stops without removal of hose or fittings . When pressurized, friction between the endcap and endcap ring may prevent rotation.
18. Unthread the bleed screw from the side of the cylinder.
19. Remove and replace the sealing washer. Reinstall the bleed screw hand tight plus ¼ turn.
20. Bleed the hydraulic system in accordance with 3.8
21. If necessary, adjust the actuator travel in accordance with 1.2
22. Perform a functional and leak test on the system in accordance with section 3.9 and 3.10

3.5 BLOCK PLATE WIPER REPLACEMENT

The block plate prevents over travel of the hydraulic piston when the assembly is not installed on an actuator. It also provides a method for centering the piston rod to ensure straight, smooth operation. The block plate has two rod wipers, one usually made of polymer material that bears the load of the piston rod, and one made of rubber that cleans contaminants from the rod. In normal applications, the wipers will not need replacement for the lifetime of the actuators. The wipers may need replacement In severe service, in highly corrosive or contaminated environments, or in the event a temperature event exceeding the max rating of the components.

WARNING

THIS PROCEDURE REQUIRES THE REMOVAL OF THE ACTUATOR’S PNEUMATIC END CAP. READ ALL ACTUATOR SPECIFIC MAINTENANCE INSTRUCTIONS BEFORE PROCEEDING.

1. Depressurize the pneumatic and hydraulic systems.
2. While this procedure may be accomplished without disconnecting hydraulic supply lines, it is not recommend. If hydraulic lines are not disconnected, always support all removed components to prevent accidental drops and line damage. Always protect component threads from damage that could prevent reassembly.
3. Remove the actuator pneumatic endcap in accordance with actuator specific instructions.
4. Position the endcap such that the outside of the hydraulic cylinder (the end with the fluid port) faces down with respect to gravity). This positioning will prevent the piston and rod from canting when the block plate is removed.
5. The block plate uses two polymer balls to lock in place. These balls are compressed against the cylinder threads until the set screws that compress them are loosened.
6. Remove the two set screws in the bottom of the block plate. On some models, a third set screw with a thru-hole is present; do not loosen that third set screw.
7. While using a spanner wrench in the unthreaded holes on the outside of the cylinder to prevent cylinder rotation, use a second spanner wrench to unthread the block plate.
8. Once halfway unthreaded, the polymer balls may fall out of the assembly. All maintenance kits include these parts. Before discarding the old parts, ensure that the new parts are available. The balls can usually be reused if necessary.



9. Use a pick to carefully remove the two wiper rings and replace them.
10. On some models, the block plate has an external o-ring. Replace the o-ring.
11. On some models, the block plate has a built-in check valve. This can be identified by a third set screw with a thru-hole that travels fully through the block plate. Check this valve according to section 3.6
12. Inspect the inside of the cylinder for contaminants and damage. If contaminants are present, carefully wipe the cylinder wall with a lint-free cloth. If the cylinder wall is visibly damaged, it may need to be replaced.
13. Slide the block plate partially onto the piston rod.
14. Apply medium strength thread locker to the external threads of the block plate.
15. Apply medium strength thread locker to the two set screw holes. Thread the set screws into the block plate fully, then unthread the set screws just far enough that the replacement polymer balls will sit fully in the side holes but do not fall into

the set screw holes. The polymer balls should not protrude further than the root of the threads to prevent interference on installation.

16. While holding the polymer balls in place, thread the block plate into the cylinder until the point of refusal. Tighten snugly with a pin-on-face type spanner wrench.
17. Tighten set screws to torque shown in table below. This will cause the polymer balls to lock against the cylinder threads without damaging them.

Hydraulic Cylinder Bore Size (inch)	Set Screw Size	Hex Drive Size	Torque ftlb (Nm)
2.0	M6-1.0	3mm	3.5 (4.7)
2.5-3.25	M8-1.25	4mm	12 (16)
4.0-4.75	M10-1.5	5mm	19 (26)

18. If the hydraulic side of the system (outer end cap, hoses, fittings, etc) was opened at any point during this procedure, bleed the hydraulic system in accordance with 3.8 If necessary, adjust the actuator travel in accordance with 1.2. Perform a functional and leak test on the system in accordance with section 3.9 and 3.10

3.6 BLOCK PLATE CHECK VALVE ADJUSTMENT (IF APPLICABLE)

On some models, the block plate may incorporate a built-in check valve to prevent air pressure building behind the hydraulic piston during actuator operation. This feature is primarily used on assemblies that are being used as dampers instead of overrides. This procedure can only be accomplished with the pneumatic endcap removed from the actuator.

**Operational check
(when block plate is not assembled to cylinder)**

1. Blow low pressure air (up to 10psig) through the small hole on the inside surface and feel for air flow on the opposite face. Air should flow in this direction
2. Blow low pressure air from the set screw hole. Air flow should be blocked in this direction.

Operational check (when block plate is assembled to cylinder)

3. Place your finger over the check valve set screw hole in the block plate.
4. Operate the cylinder until pressure builds behind your finger, this indicates that the check valve is allowing air to flow properly. Remove your finger and the pressure should release.
5. Place your finger over the hole again. Release the pressure from the hydraulic cylinder and push the piston inward rod until fully retracted. You should NOT feel vacuum pulling on your finger.

**Adjustment
– Only adjust if the check valve failed the previous test**

If air is blocked when blowing from the small hole to the set screw, the orifice may be blocked by debris or contaminants, or the set screw may be threaded in too far. If air flows freely from the set screw to the small orifice, the sealing ball or spring may be damaged, or the set screw may be threaded out too far.

6. Measure and record the distance between the block plate and the set screw.
7. Remove the set screw, the spring, and the rubber ball.
8. Inspect the orifice to ensure there is a clear pathway
9. Inspect the rubber ball for damage, replace if necessary.
10. Inspect the spring for damage, replace if necessary.
11. Install the rubber ball and spring.
12. Apply medium strength threadlocker to the set screw and reinstall in the same orientation and to the same distance as

when removed. The small vent hole on the set screw should be on the inside when installed.

13. Test the system again. If air does not flow from the small orifice to the set screw hole, unthread the set screw 1 full turn and retest.

14. If air flows from the set screw to the small orifice, thread the set screw inward 1 full turn and retest.

15. Repeat steps 14-15 until proper flow is achieved in both directions.

3.7 FLUID MANAGEMENT

In normal applications when using the system as an override only, the hydraulic fluid will not need replacement for the lifetime of the actuator. The fluid may need replacement in severe service, in highly corrosive or contaminated environments, or in the event a temperature event exceeding the max rating of the components.

3.8 BLEEDING THE SYSTEM

WARNING

BLEEDING THE HYDRAULIC SYSTEM MAY ALLOW SMALL AMOUNTS OF HYDRAULIC FLUID TO EXIT THE ASSEMBLY. FLUID MAY EXIT THE ASSEMBLY AT HIGH VELOCITY. ALWAYS WEAR PERSONAL PROTECTIVE EQUIPMENT INCLUDING SAFETY GOGGLES. NEVER USE YOUR HANDS TO CHECK FOR LEAKS OR MONITOR THE BLEED SCREW, EVEN WHEN WEARING GLOVES.

After performing any maintenance that opened the hydraulic system, it is important to bleed the system of air that could make the cylinders action soft and unresponsive.

This procedure requires rotating the hydraulic cylinders, affecting actuator travel. For dual cylinder models, this can be done one cylinder at a time to maintain travel adjustment. When bleeding the cylinders one at a time, move the hydraulic lines of the first cylinder below (with respect to gravity) the level of the second cylinder.

If rotating the hydraulic cylinders is not practical due to site conditions, it is acceptable to bleed the system at hose connections only.

1. Ensure that the hydraulic reservoir is filled to the proper level.
2. Pressurize the hydraulic system and check for leaks. Bleeding the system is useful only after the system is confirmed to be leak free.
3. Depressurize the system.
4. Mark the angle of the hydraulic cylinder(s) with reference to the pneumatic endcap.
5. Loosen the spanner nut on the first hydraulic cylinder. Rotate one hydraulic cylinder such that the bleed screw is facing up with respect to gravity. This may require applying low pressure air to P1 and P2 to remove spring load from the cylinders.
6. Loosen the bleed screw ½ turn.

7. Slowly pressurize the system with the hand pump, or if using a hydraulic power supply pressurize only to pressures less than 100psig. Air will exit around the bleed screw, followed by fluid. Once fluid begins to flow, tighten the bleed screw hand tight plus ¼ turn. When using the hand pump, the bleed screw should be tightened in the middle of a stroke to remove the maximum amount of air from the system.
8. Rotate the cylinder back to the correct position as previously marked. At this position on dual cylinder models, the hydraulic cylinder should be about the pneumatic piston inside of the actuator.
9. For dual cylinder models, repeat steps 4-8 for the second cylinder.
10. Test the system for leaks.

3.9 PRESSURE RELIEF VALVE ADJUSTMENT

WARNING

NEVER ADJUST THE PRESSURE RELIEF TO A VALUE HIGHER THAN THE LOWEST MAXIMUM OPERATING PRESSURE OF ALL SYSTEM COMPONENTS. WHEN ADJUSTING TO HIGHER PRESSURES, MAKE FINE ADJUSTMENTS. WHEN TESTING PRESSURE ADJUSTMENTS, PUMP SLOWLY WHEN APPROACHING THE LOWEST MOP AND STOP PUMPING IF THE MOP IS REACHED.

NOTE:

THE TIME TO CARRY OUT THIS PROCEDURE MAY BE REDUCED BY DISCONNECTING THE PUMP FROM THE HYDRAULIC SYSTEM AND CAPPING THE OUTPUT PORT.

The pump pressure relief is set to the proper value at the factory. Changing the pressure relief setting is not necessary except in rare cases. Do not change the pressure relief setting unless instructed to do so by the manufacturer.

1. Relieve all pressure from the system.
2. Remove the adjustment cap. The cap is located on the side of the hydraulic pump.
3. To increase the relief pressure, thread the adjustment screw inward (clockwise).
4. To decrease the relief pressure, thread the adjustment screw outward (counterclockwise).
5. Replace the adjustment cap.
6. Test the pressure relief value.

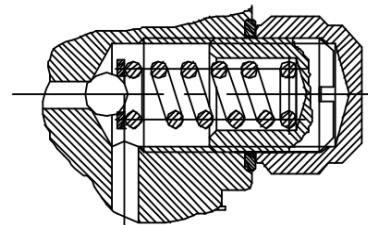
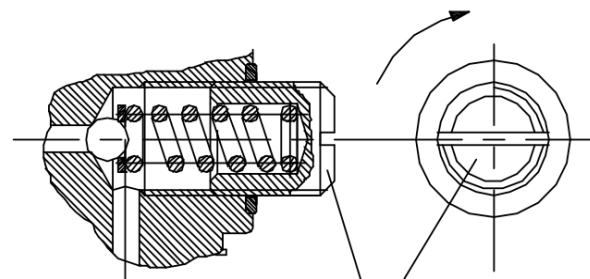
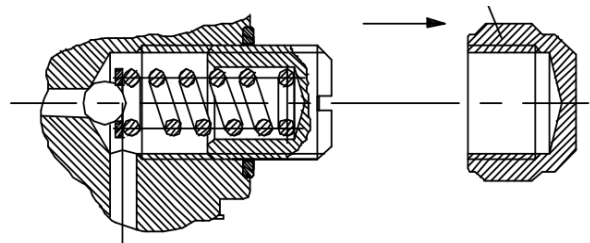
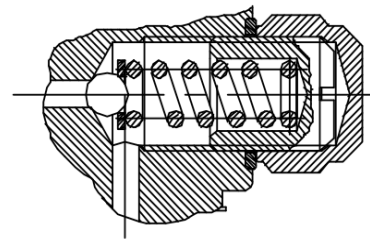

Pressure Relief Valve

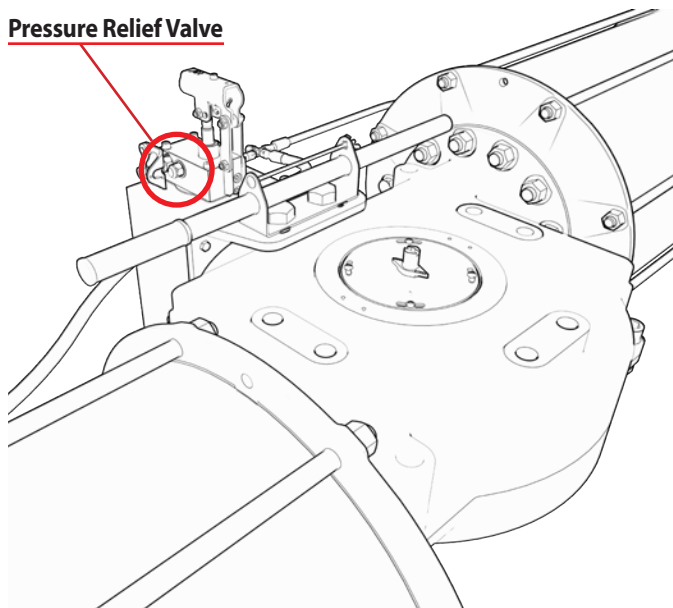



3.10 LEAK TEST

WARNING

PRESSURIZED HYDRAULIC FLUID MAY EXIT FROM WORN HOSES OR OTHER LEAK POINTS AT HIGH VELOCITY. ALWAYS WEAR PERSONAL PROTECTIVE EQUIPMENT INCLUDING SAFETY GOGGLES. HIGH VELOCITY HYDRAULIC FLUIDS HAVE BEEN KNOWN TO INJECT FLUID THROUGH THE SKIN, EVEN WHEN WEARING THICK LEATHER GLOVES AND AT DISTANCES UP TO FOUR INCHES FROM THE LEAK POINT. NEVER USE YOUR HANDS TO CHECK FOR LEAKS, EVEN WHEN WEARING GLOVES.

Leak tests should be conducted up to the maximum operating pressure of the system.

For systems with hand pumps

The hand pump pressure relief is set to within 5% of the system MOP at the factory.

1. Pressurize the system with the hand pump until the pressure relief point is met. When approaching this point, the pump handle will become more difficult and the pressure will not increase regardless of the number of strokes.
2. Wait 60 seconds
3. If the system has a pressure gauge installed, record the pressure.
4. Wait 10 minutes
5. Visually check for leaks at all interfaces. Note any leaks.
6. If the system has a pressure gauge installed, record the pressure.
7. Depressurize the system before correcting leaks.
8. If there is a measurable drop in system pressure, investigate for leaks and correct appropriately.

3.11 FUNCTIONAL AND OPERATION TEST

The functional test may be performed at the same time as the leak test.

1. Pressurize the system until the actuator is at the extents of travel.
2. Observe for sticking or jumping. Investigate cause if observed.
3. Slowly relieve pressure and observe for sticking or jumping. Investigate cause if observed.

3.12 PUMP CONTROL KNOB LOCKOUT

Systems provided with a hydraulic pump and reservoir are also provided with a control knob lockout. The lockout allows a user to prevent operation of the hand pump when such operation would be undesirable. To install the lockout:

1. Disengage the pump control knob by turning counterclockwise. This will depressurize the system if pressurized.
2. Slide the lockout between the pump control knob and the pump body. When installed properly, one arm of the locking knob will be trapped in a slot in the side of the lockout.
3. Swing the locking plate into place. When placed properly, this should also be between the control knob and pump body. This may require further disengaging the pump control knob.
4. Using a lock, shackle, or other device according to local policy to secure the locking plate. The lockout has two holes available for locking, one for shackles of $\frac{3}{8}$ inch diameter and one for shackles of $\frac{1}{4}$ inch diameter.
5. Always test the pump handle after the lockout is installed. The pump handle should move freely without pressurizing the system. If the pump handle resists movement and pressurizes the system, the lockout is not properly installed and not secure.



4. APPENDIX

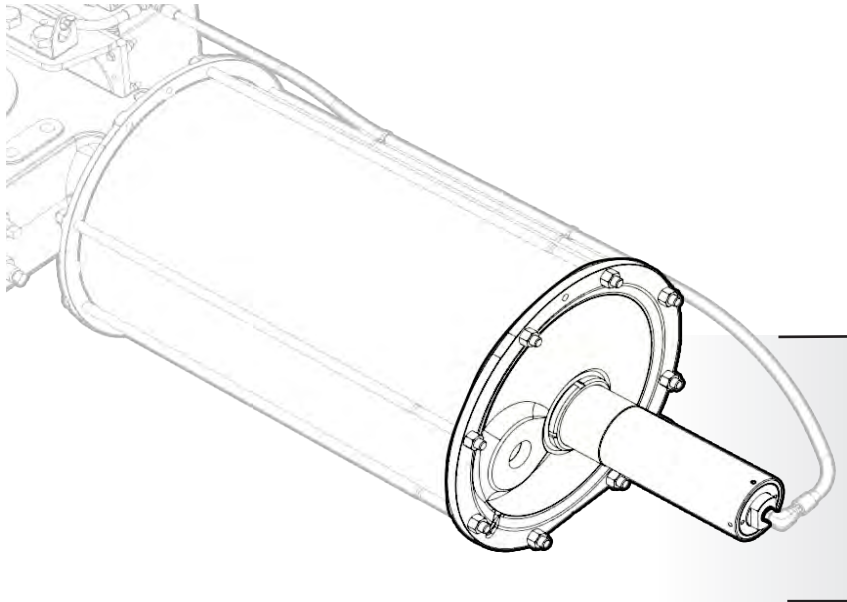

NUMBER	PART
1	End Cap Ring
2	End Cap
3	Back Up Ring
4	Piston Ring
5	O-Ring
6	Piston
7	Piston Ring
8	Piston O-Ring
9	Piston Back Up Ring
10	Piston Retaining Ring
11	Push Rod
12	End Cap Ring Set Screw
13	Bonded Seal Washer
14	Bleed Screw
15	Cylinder
16	Spanner Nut
17	Rod Ring
18	Rod Wiper
19	Block Plate
20	Locking Ball
21	Block Plate Set Screw

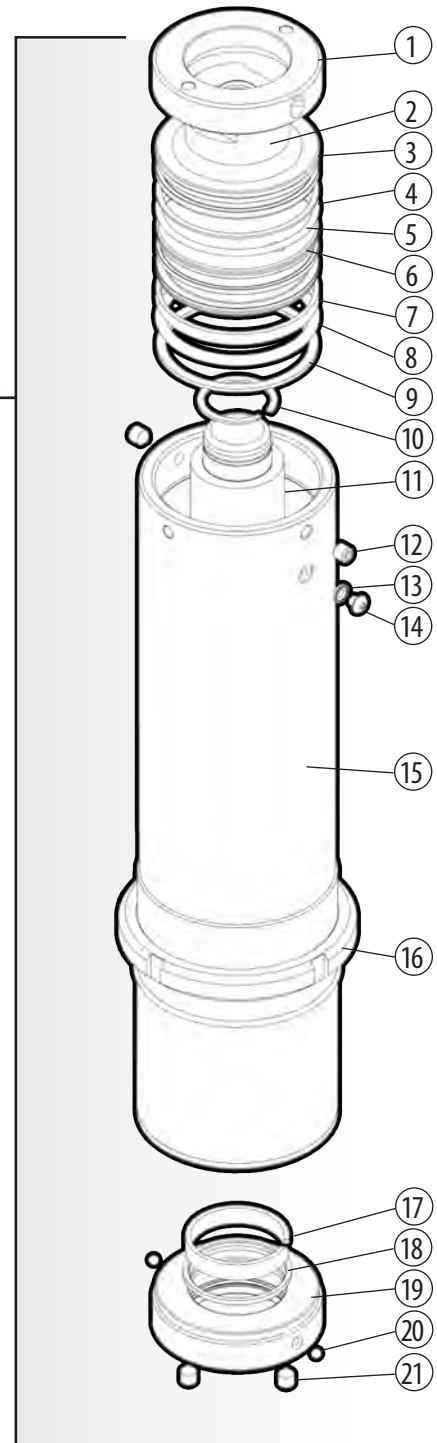



The Leader in Actuator Technology

QTRCO, Inc. | phone (281) 516-0277
13120 Theis Lane • Tomball, TX 77375 USA

 **888.ACTU.8.IT**
888.228.8848

 **www.qtrco.com**
Email: actu8it@qtrco.com

DCN04087(1)